

T Level Technical Qualification in Digital Support Services

Employer-set project (ESP)

Core skills

Digital Infrastructure & Network Cabling

Project brief

T Level Technical Qualification in Digital Support Services Employer-set project (ESP)

Core skills

Project brief

Digital Infrastructure & Network Cabling

Contents

Student instructions	4
Student information	4
Plagiarism.....	4
Presentation of work	4
Scenario	6
Brief	6
Task 1: 2 hours 30 minutes	7
Scenario	7
Instructions for students	7
Evidence required for submission to NCFE	7
Additional guidance	8
Task 2: 2 hours 10 minutes	9
Scenario	9
Instructions for students	9
Evidence required for submission to NCFE	9
Additional guidance	10
Task 3: 4 hours	11
Scenario	11
Instructions for students	11
Evidence required for submission to NCFE	11
Additional guidance	11
Task 4: 3 hours 30 minutes	13

Scenario	13
Instructions for students	13
Evidence required for submission to NCFE	13
Additional guidance	13
Control document A: logical topology diagram – Southampton office (task 1)	15
Control document B: logical topology diagram – York office (task 1).....	16
Control document C: TechSys router port forwarding configuration (task 1)	17
Control document D: specification of requirements (controlled document to be issued at the start of task 3)	18
Network setup	18
Southampton office	18
York office	18
Document information	19
Change History Record	19

SAMPLE

Student instructions

- read the project brief carefully before starting your work
- you must work independently and make your own decisions as to how to approach the tasks within the employer-set project
- you must clearly name and date all of the work that you produce during each supervised session
- you must hand over all of your work to your tutor at the end of each supervised session
- you must not work on the assessment in between supervised sessions

Student information

- the employer-set project will assess your knowledge, understanding and skills from across the core content of the qualification
- in order to achieve a grade for the core component, you must attempt both of the external examinations and the employer-set project
- the combined marks from these assessments will be aggregated to form the overall core component grade (A* to E and U) – if you do not attempt one of the assessments, or fail to reach the minimum standard across all assessments, you will receive a U grade
- the maximum time you will have to complete all tasks for the employer-set project is 12 hours 10 minutes
 - your tutor will explain how this time is broken down per task and will confirm with you if individual tasks need to be completed across multiple sessions
 - at the end of each supervised session, your tutor will collect all employer-set project assessment materials before you leave the room
 - you must not take any assessment material outside of the room (for example, via a physical memory device)
 - you must not upload any work produced to any platform that will allow you to access materials outside of the supervised sessions (including email)
- you can fail to achieve marks if you do not fully meet the requirements of the task, or equally if you are not able to efficiently meet the requirements of the task
- the project is assessed out of a total of 76 marks (this includes 2 marks for your use of maths in task 3, and 4 marks for your use of English throughout tasks 2, 3 and 4) – the individual task marks are also shown throughout the project brief booklet at the start of each task

Plagiarism

Plagiarism may result in the external assessment task being awarded a U grade.

For further guidance, refer to your student handbook – plagiarism guidance and maladministration and malpractice policy located at www.qualhub.co.uk.

Presentation of work

- all of your work should be completed electronically using black font, Arial size 12pt unless otherwise specified

- any work not produced electronically must be agreed with your tutor, in which case the evidence you produce should be scanned and submitted as an electronic piece of evidence
- all your work should be clearly labelled with the relevant task number and your student details and be legible (for example, front page and headers)
- electronic files should be named using the following format – Surname_Initial_student number_evidence reference for example: Smith_J_123456789_Task1 for identification purposes – where evidence reference is shown, this should be replaced with the task number for which the work reflects and saved as a .pdf format
- all pages of your work should be numbered in the format page X of Y, where X is the page number and Y is the total number of pages
- you must complete and sign the external assessment cover sheet (EACS) and include it at the front of your assessment task evidence
- you must submit your evidence to the supervisor at the end of each session

SAMPLE

Scenario

You are working as an infrastructure technician for Willow Technology.

Willow Technology currently operates from offices in Southampton and has recently opened a satellite office in York. Remote workers access company resources by connecting via virtual private network (VPN) configured at the Southampton office, allowing access to shared files and resources. York workers are currently treated as remote workers.

Staff are complaining that access to the VPN is unreliable and is becoming more so as the company is growing. Currently, connectivity has been lost completely and users are simply receiving the following error:

Cannot connect to Willow VPN. The connection was terminated by the remote computer before it could be completed.

Brief

As part of your role you are involved in a large, infrastructure project but have also been asked to support with a recurring connectivity issue faced by end users.

Once you have resolved the initial connectivity issue, you should research and propose an effective solution that will support the wider infrastructure project with the aim of facilitating remote staff at the York office to utilise resources from the main Southampton site efficiently.

Task 1: 2 hours 30 minutes

You must read the information on all pages provided for this task before starting your response.

(22 marks)

Scenario

Your line manager has asked you to investigate the issues the York staff are having. As you are working remotely, you have been provided with a topology diagram (control documents A and B) that show the current network configuration. This will allow you to troubleshoot issues and plan your changes to the network. You also have a copy of the current configuration page (control document C) for the router firewall.

Due to working remotely, your line manager has asked you to show your proposed changes required to resolve the issue on the firewall configuration document (control document C) and design a test plan that could be followed, by a colleague in the office, to test the changes made have resolved the issue.

Instructions for students

Using the information provided above and control documents A, B and C, you should investigate and identify the root cause of the issue and add your required steps to resolve the fault onto the configuration page (control document C) (6 marks).

You should consider:

- use of troubleshooting frameworks
- tools used during the troubleshooting process

Your test plan document (16 marks) should include:

- user details
- test dates
- computer specification and software
- proposed tests
- expected outcomes of tests
- ability to record changes based on test outcomes
- record of diagnosis
- user acceptance of work completed

Evidence required for submission to NCFE

- firewall configuration document (control document C) with any of your proposed changes in .pdf format
- test plan document to be submitted at the end of task 1 in .pdf format

When you have completed this task, you should save in a .pdf format, and name your file:

- Surname_Initial_student number_evidence reference for example: Smith_J_123456789_Task1

Additional guidance

For this task you will be issued with control documents A, B and C.

You will have access to a word processing application or other suitable software to enable you to complete this task.

Access to the internet is permitted.

Access to any online cloud storage is not permitted.

Use of online chat or emails is not permitted.

Access to previous class notes/teaching materials is not permitted.

SAMPLE

Task 2: 2 hours 10 minutes

You must read the information on all pages provided for this task before starting your response.

(12 marks)

Scenario

Now you have resolved the current network issue, your line manager has asked you to investigate the wider problems that are occurring with remote connectivity on the network.

You have been asked to put forward recommendations on resolving the issues, therefore you need to gather information that will help you plan your recommendations.

You organise a meeting with Willow Technology's York network manager to discuss requirements for remote access and better understand the overall network usage and problems. Before the meeting, you decide to prepare some questions that will help you gather the appropriate information in the meeting.

After your meeting, you must update your line manager (technical audience) and the facilities manager (non-technical audience) of the York office

with your findings by sending them each an email.

Instructions for students

The meeting with the York network manager will be a recorded, simulated interview in which your tutor will play the role of the York network manager and will last no longer than 10 minutes (6 marks).

The total time for the task is 2 hours 10 minutes which will be broken down as follows:

You will be allocated 1 hour to prepare your questions.

You should:

- prepare a list of key questions you want to ask to gather information from the York network manager prior to your meeting with them

You will be allocated 10 minutes to conduct your interview.

After your meeting with the York network manager, you need to email your own line manager and the company facilities manager with your findings (6 marks). You have the remaining 1 hour to complete both emails.

You should email your line manager (technical audience) to:

- outline any questions and responses you have used or gathered
- summary of key issues identified

You should email the facilities manager (non-technical audience) to:

- include an overview of the issues that have been identified that can be sent company wide as part of a business update

Evidence required for submission to NCFE

- the York network manager interview audio recording (saved as an appropriate audio file, for example MP3)

- email to line manager detailing questions asked, responses and summary of issues that have been identified (on email template document) in .pdf format
- email to facilities manager with an overview of the issues that have been identified (on email template document) in .pdf format
- all completed work must be submitted at the end of this task

When you have completed this task, you should save in a .pdf format, and name your file:

- Surname_Initial_student number_evidence reference for example: Smith_J_123456789_Task2

Additional guidance

This task will also assess your English skills.

You will have access to a word processing application or other suitable software to enable you to complete this task.

Use the email template provided to construct your emails: do not use your own email account.

Access to the internet is permitted.

Access to any online cloud storage is not permitted.

Use of online chat or emails is not permitted.

Access to previous class notes/teaching materials is not permitted.

Task 3: 4 hours

You must read the information on all pages provided for this task before starting your response.

(24 marks)

Scenario

Following your meeting with the York network manager, you have been provided with a full specification of requirements (control document D) for remote connectivity for remote workers and workers based at the York site by your line manager (technical audience). The York sites will house both permanent members of staff and some remote workers who will require access to network services.

Your line manager has asked you to prepare a project proposal and a network diagram, using the specification of requirements, detailing how you will resolve the connectivity issues identified for the staff located in the York office.

Instructions for students

Your project proposal (24 marks) should include:

- an introduction outlining the current issues for remote connectivity
- a detailed overview of how to upgrade the network to improve connectivity and access to the network
- your proposed solution detailed on a network diagram which accompanies the proposal
- a justification of any equipment, software or cloud services decision you make
- estimated costs for any equipment, software or cloud services recommended; your decisions should provide value for money whilst meeting the brief (you should use the internet to research this)
- an explanation of any potential network security issues with justification for recommended mitigations
- a final summary

When identifying costs, the company usually uses PC World Business and Dell as preferred suppliers. Where possible, these suppliers should be used for all equipment or software recommendations before considering other suppliers.

Evidence required for submission to NCFE

- a detailed project proposal in .pdf format
- a detailed network diagram in .pdf format

When you have completed this task, you should save in a .pdf format, and name your file:

Surname_Initial_student number_evidence reference for example: Smith_J_123456789_Task3

Additional guidance

For this task you will be issued with control document D.

This task will also assess your English skills.

This task will also assess your mathematical skills which are worth 2 marks.

You will have access to a word processing application or other suitable software to enable you to complete this task.

Access to the internet is permitted.

Access to any online cloud storage is not permitted.

Use of online chat or emails is not permitted.

Access to previous class notes/teaching materials is not permitted.

You are permitted to have up to a maximum of 15 minutes rest break during this task. This must be supervised.

SAMPLE

Task 4: 3 hours 30 minutes

You must read the information on all pages provided for this task before starting your response.

(12 marks)

Scenario

The network upgrade project is nearing its completion and Willow technology are considering implementing your proposals.

Your line manager (technical audience) wants you to prepare for a post-project review and create a sample satisfaction survey that could be used to test end users' satisfaction and measure if your solution fulfils the desired outcomes.

Instructions for students

You should create a sample satisfaction survey (6 marks) that:

- is professionally formatted and suitable to be distributed to non-technical customers
- includes a range of questions to check ease of use, stability of the network, ability to access files and folders and overall satisfaction with the network

Your post-project review (6 marks) should include:

- a brief overview of the key issues present in the network upgrade project
- your identified solution
- any security concerns you have mitigated
- a brief evaluation of your own performance, including areas that could be developed or improved in a future project

Evidence required for submission to NCFE

- a sample satisfaction survey document in .pdf format
- a post-project review summary document in .pdf format

When you have completed this task, you should save in a .pdf format, and name your file:

- Surname_Initial_student number_evidence reference for example: Smith_J_123456789_Task4

Additional guidance

This task will also assess your English skills.

You will have access to a word processing application or other suitable software to enable you to complete this task.

You will have access to all of your completed employer-set project tasks for this task apart from the interview audio recording.

Access to the internet is permitted.

Access to any online cloud storage is not permitted.

Use of online chat or emails is not permitted.

Access to previous class notes/teaching materials is not permitted.

You are permitted to have up to a maximum of 15 minutes rest break during this task. This must be supervised.

SAMPLE

Control document A: logical topology diagram – Southampton office (task 1)

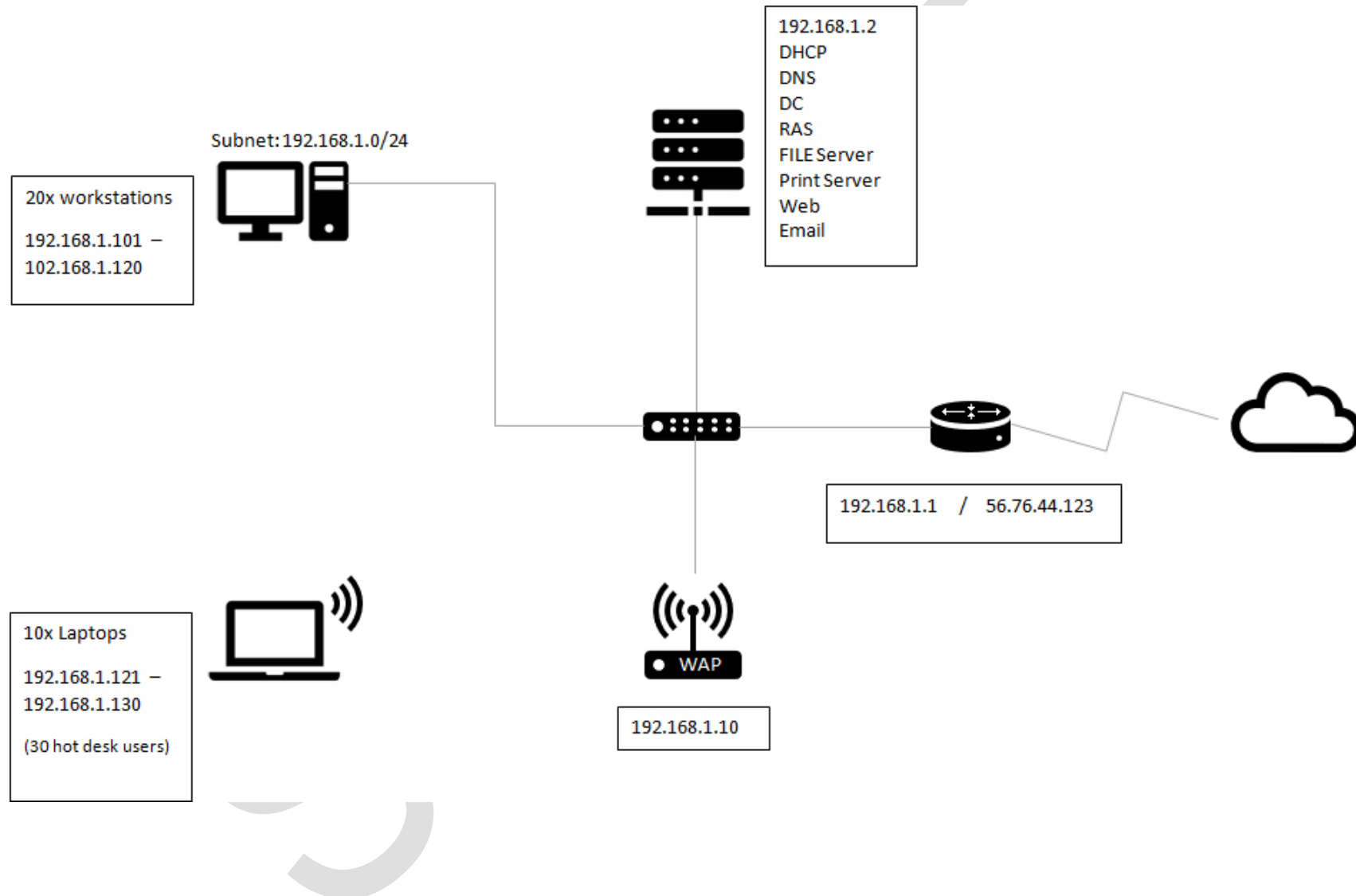

Control document B: logical topology diagram – York office (task 1)

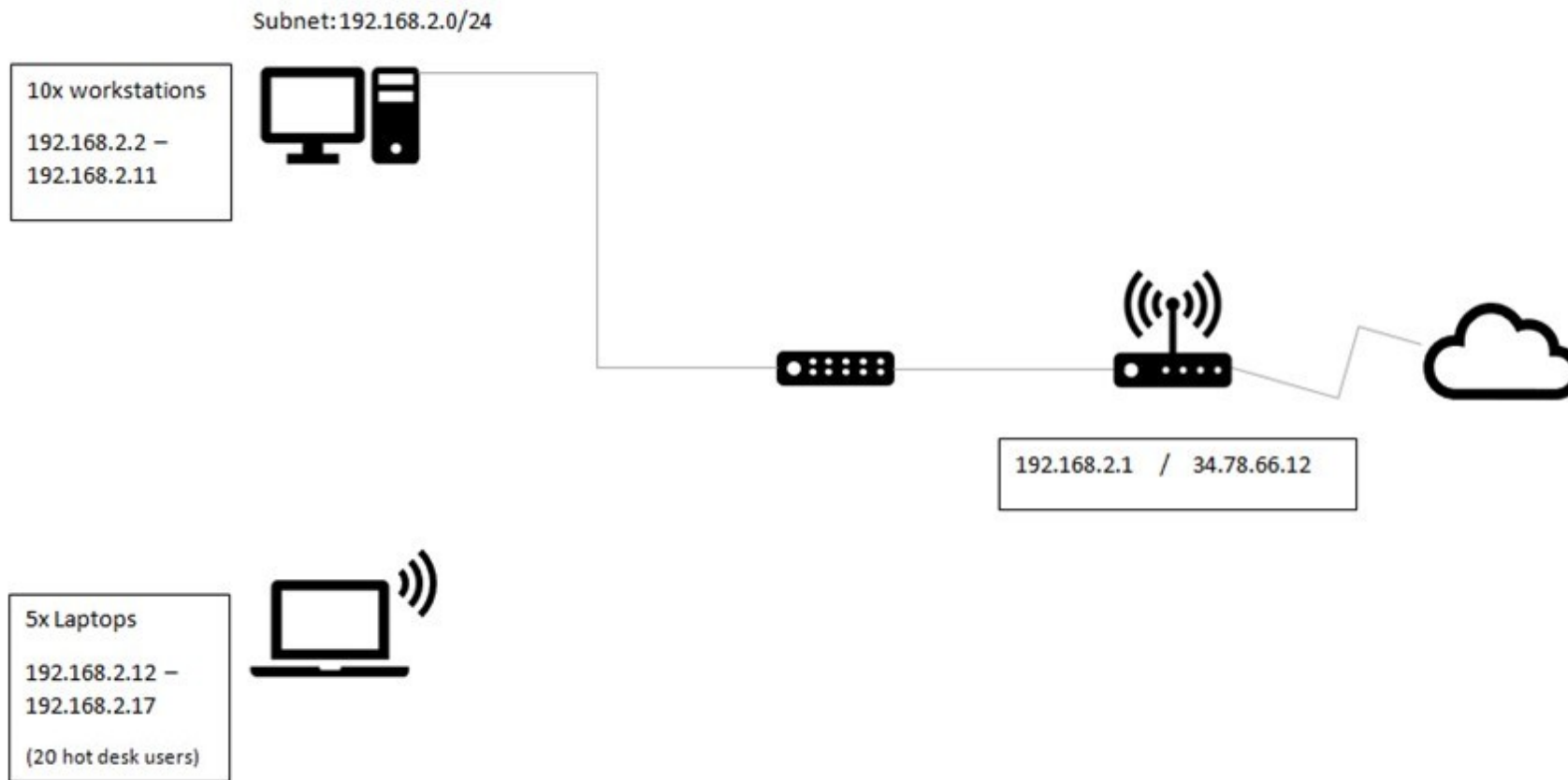

Control document C: TechSys router port forwarding configuration (task 1)

Enable	Service	Protocol	External IP	Internal IP	External port	Internal port
<input checked="" type="checkbox"/>	HTTP	TCP	*	192.168.1.2	80	80
<input checked="" type="checkbox"/>	POP3	TCP	*	192.168.1.2	143	143
<input checked="" type="checkbox"/>	SMTP	TCP	*	192.168.1.2	25	25
<input type="checkbox"/>	-----	UDP	0.0.0.0	0.0.0.0	-----	-----
<input type="checkbox"/>	-----	Select Protocol	0.0.0.0	0.0.0.0	-----	-----

Control document D: specification of requirements (controlled document to be issued at the start of task 3)

Network setup

Southampton office

Network includes a single server running Windows Server 2016 which currently holds the following roles:

- DHCP
- DNS
- domain controller
- VPN server (allowing PPTP connectivity to the network – capacity for 50 concurrent connections)
- file server
- print server
- web server (for internal intranet)
- email server (IMAP and SMTP)

The internet service provider at the Southampton office has recently been updated and the perimeter router and firewall have been replaced.

The Southampton office supports approximately 20 staff full time, including senior management, finance and IT.

Hot desk facilities include 10 desks for ad hoc use by the 30 remote workers located in the South of England who will be using company issued laptops to access the network.

York office

This is a new office and currently only contains a simple LAN with a single SOHO router providing services to the network, including DHCP and DNS. There is no domain control in York. Staff are connecting via VPN to the Southampton site each day to access necessary resources.

There are approximately 10 staff permanently located in the York office as well as a further 5 hot desks to support 20 remote workers.

Network topology and configuration is detailed in the accompanying current network topology and firewall configuration documents.

Requirements for the updated network

Technology should be used to connect the York and Southampton networks, with all users able to access file shares and other network resources adequately.

All remote workers should be able to connect to the network remotely via VPN, or similar, to access network resources. Connection dropouts and lack of VPN availability should be minimised.

Protocols used for VPN software should be secure.

VPN traffic should not endpoint inside the Southampton network.

Document information

The T Level Technical Qualification is a qualification approved and managed by the Institute for Apprenticeships and Technical Education.

Copyright in this document belongs to, and is used under licence from, the Institute for Apprenticeships and Technical Education, © 2020–2023.

'T-LEVELS' is a registered trade mark of the Department for Education.

'T Level' is a registered trade mark of the Institute for Apprenticeships and Technical Education.

'Institute for Apprenticeships & Technical Education' and logo are registered trade marks of the Institute for Apprenticeships and Technical Education.

Owner: Head of Assessment Design

Change History Record

Version	Description of change	Approval	Date of Issue
v1.0	Post approval, updated for publication.		December 2020
v1.1	Branding and formatting final updates. NCFE rebrand.		September 2021
v1.2	Sample added as a watermark	November 2023	15 November 2023